

# D Series Motors

Frameless Brushless DC Motors

**Nidec**  
MOTION & DRIVES

Lightweight, frameless motors delivering low inertia, high efficiency and high torque density in compact sizes for applications in the fields of robotics, automation, medical, industrial, semiconductors and more.

## Motor Specifications

**Torque Range (Continuous):** 0.145 Nm to 2.97 Nm

**Torque Range (Peak):** 0.457 Nm to 9.68 Nm

**Power:** 73 W to 498 W

**Warranty:** One-year limited warranty

## Product Overview

What makes frameless brushless DC motors so unique, is their versatility in a wide range of applications. For instance, frameless BLDC motors fit more easily into a vast array of smaller machines that require precision and higher torque density. Additionally, they're increasingly used to replace heavier, less efficient hydraulic components in machines, making them cost less to operate and maintain, with the added benefit of being more environmentally friendly. Whatever your application requirements are, Nidec Motion and Drives has a generous selection of standard and custom BLDC frameless motor solutions to choose from.

## Product Features

- High torque to inertia ratio for quick responsiveness and precision control
- High torque density in a space-saving package
- Large rotor interior diameter for convenient cable routing
- Standard 200 mm lead lengths
- Low cogging torque for a smooth, steady operation
- Machine wound for high reliability with bondable magnet wire for a compact, self-supporting coil
- Constructed with corrosion-inhibitive materials
- Supported by rigorous testing for performance and reliability
- Manufactured by the world's most comprehensive electric motor manufacturer
- On-hand Inventory availability and short lead times
- Class F insulation
- UL agency recognition
- RoHS compliant
- **Custom Designs Available**

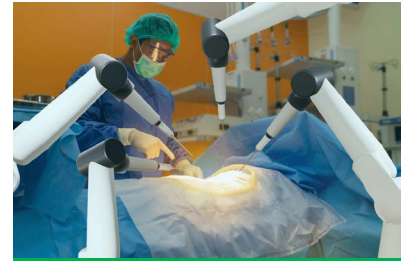

Surgical Robots

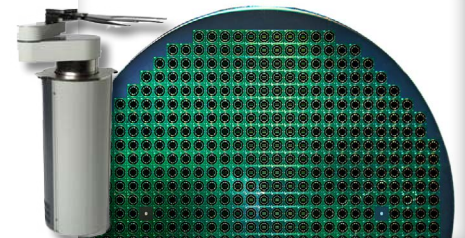

Semiconductor Wafer-Handling



Manufacturing Automation



Autonomous Guided Vehicles



Scanners and Printers

Collaborative Robots



Machining Equipment

**Nidec**  
NIDEC MOTOR CORPORATION

# D Series Motors

## Frameless Brushless DC Motors

### Specifications

Part Number	D35	D52	D64	D77	D100
Standard bus voltage (Vdc)	48	48	48	48	48
Standard stack heights (mm)	20.5	18.5	25.5	28	32
<b>Data Below is Based on Standard Stack Height at 48V</b>					
Rated Speed (RPM)	4800	2400	2400	2400	1600
No-load Speed (RPM)	10000	4500	3500	3300	2900
Rated torque (Nm)	0.145	0.39	0.76	1.69	2.97
Continuous Stall Torque (Nm)	0.183	0.46	0.86	1.88	3.23
Peak torque (Nm)	0.457	1.38	2.59	5.63	9.68
Rated power (W)	73	98	191	425	498
Ke (Vrms/kRPM)	3.21	7.42	9.55	10.15	11.44
Kt (Nm/Arms)	0.053	0.123	0.158	0.168	0.189
Rated current (Arms)	3.14	3.61	5.41	11.19	17.44
Peak current (Arms)	9.68	12.46	18.03	36.47	55.63
Standard inertia (kgcm <sup>2</sup> )	0.013	0.047	0.158	0.45	1.6
Stator insulation rating (deg C)	155	155	155	155	155
Stator weight (kg)	0.077	0.172	0.417	0.635	1.193
Rotor weight (kg)	0.027	0.045	0.099	0.158	0.326
Number of poles	6	6	8	10	10
R (ph-ph) (Ohms)	2.41	1.6	0.752	0.244	0.1
L (ph-ph) (mH)	1.4	2.5	1.51	0.74	0.33
Air gap (mm)	0.50	0.50	0.50	0.50	0.76

**Custom Designs Available**

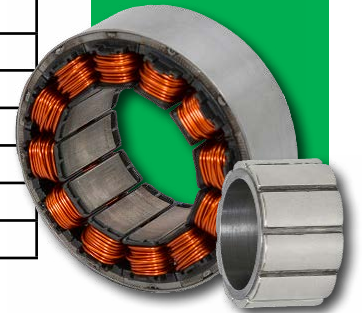

### Motor Dimensions D35

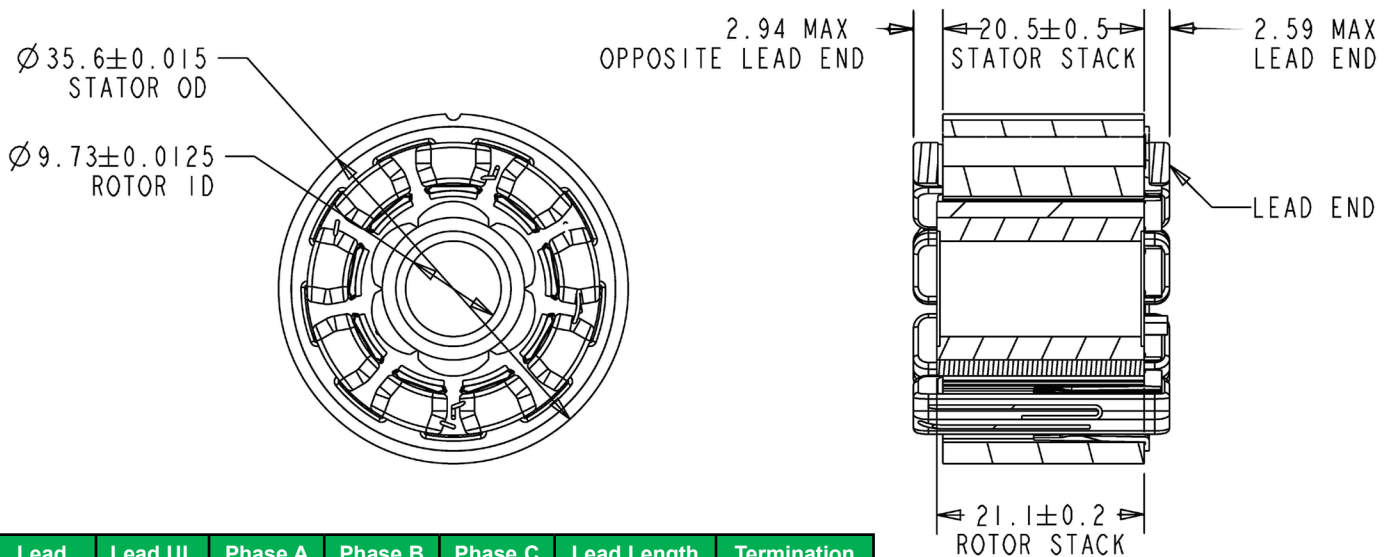

Lead Gauge	Lead UL Style	Phase A Color	Phase B Color	Phase C Color	Lead Length (mm)	Termination
26 AWG	UL 1180	Blue	Brown	Violet	200	None

# D Series Motors

Frameless Brushless DC Motors

## Motor Dimensions D52

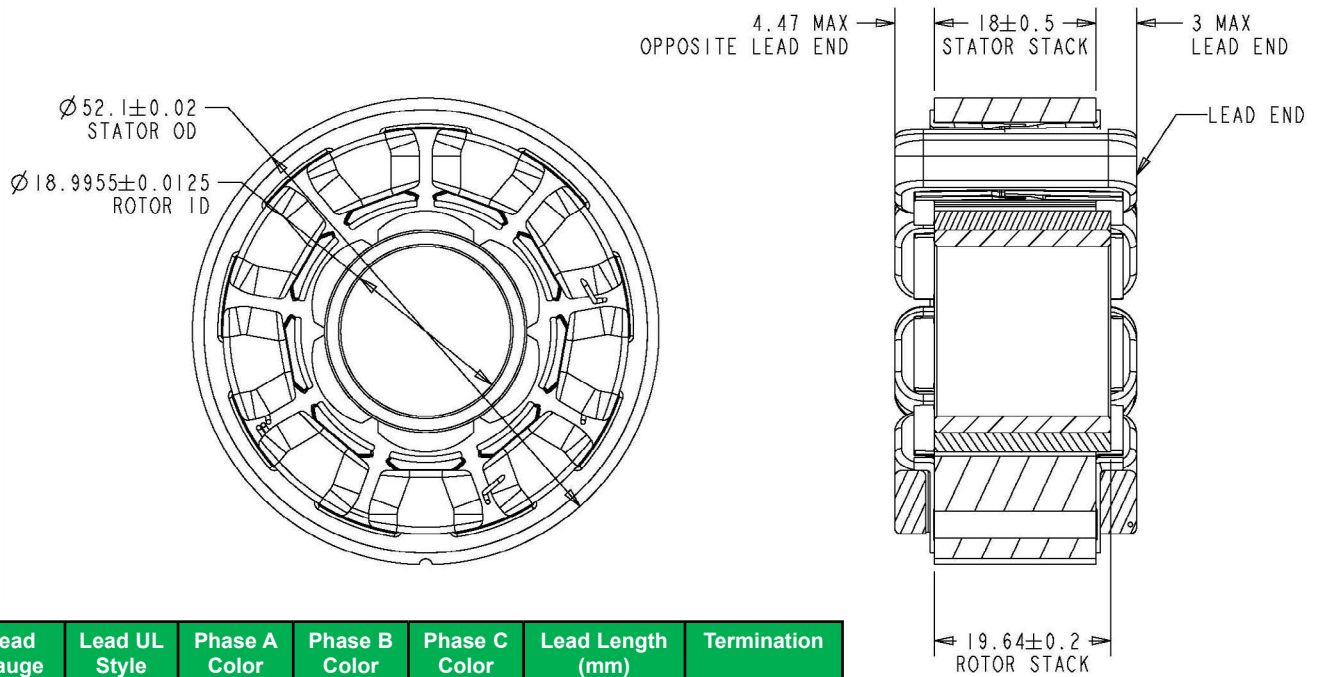

## Motor Dimensions D64

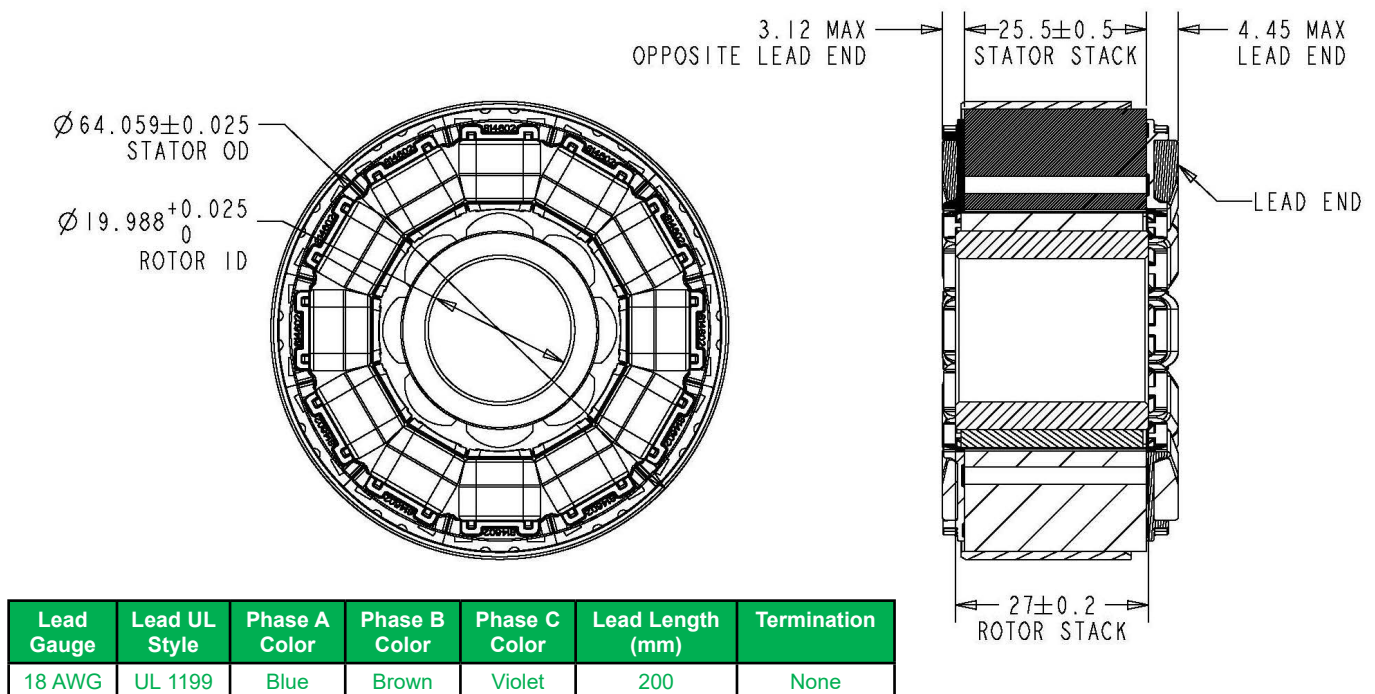

# D Series Motors

Frameless Brushless DC Motors

## Motor Dimensions D77

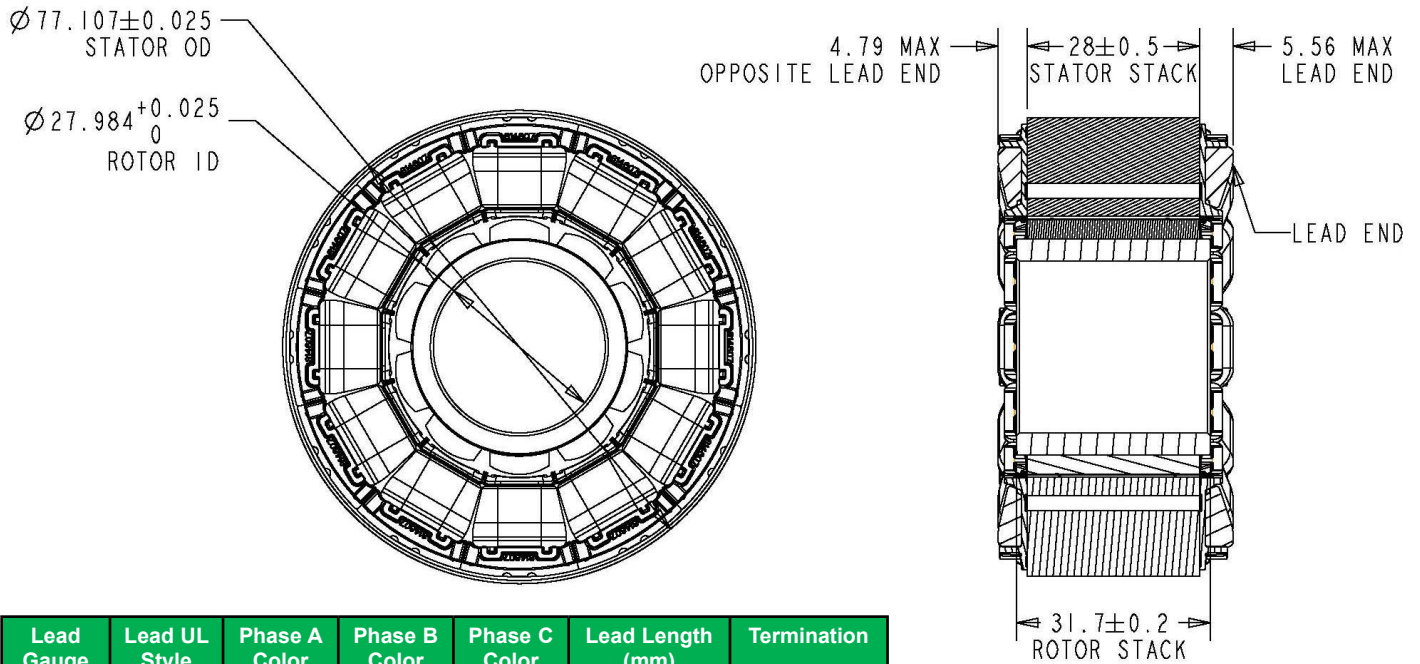

Lead Gauge	Lead UL Style	Phase A Color	Phase B Color	Phase C Color	Lead Length (mm)	Termination
18 AWG	UL 1199	Blue	Brown	Violet	200	None

## Motor Dimensions 100

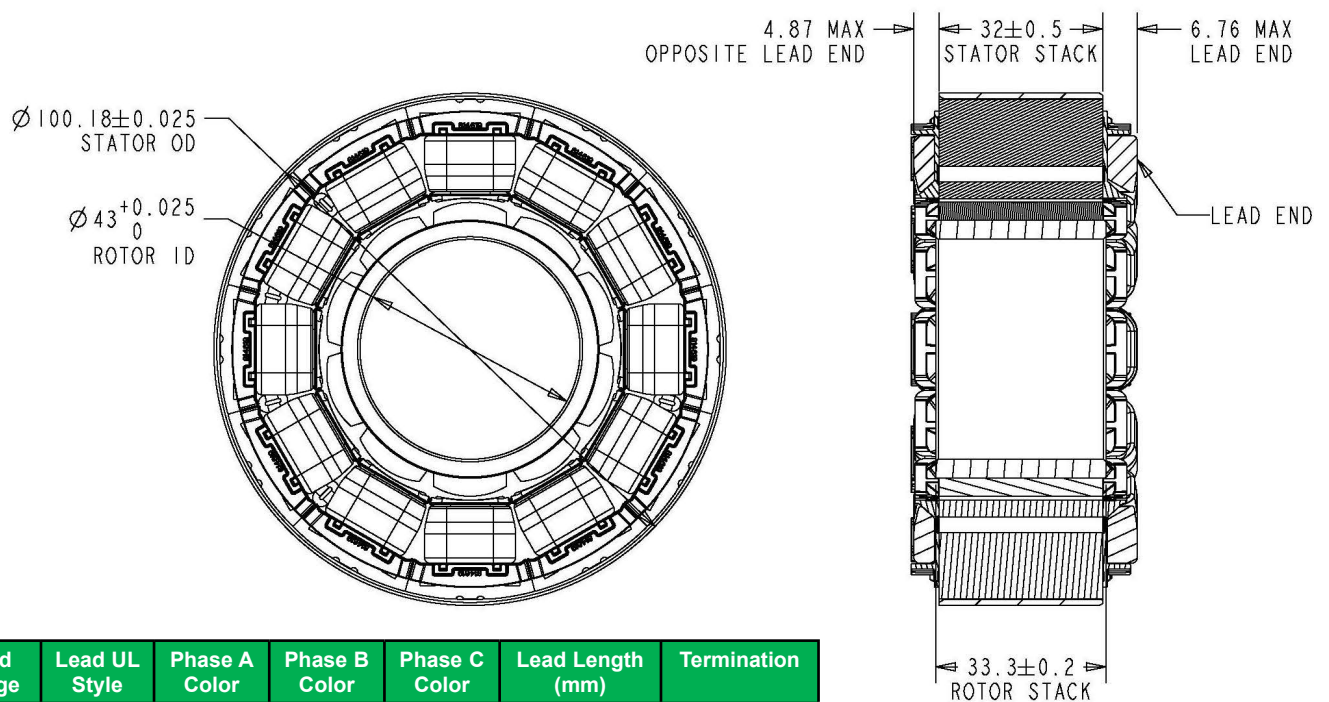

Lead Gauge	Lead UL Style	Phase A Color	Phase B Color	Phase C Color	Lead Length (mm)	Termination
14 AWG	UL 1199	Blue	Brown	Violet	200	None

# Mounting & Installation Guidelines

Frameless Brushless DC Motors

## Important Safety Notes

Use caution when handling motor parts. Strong magnetic fields pose a hazard for sensitive individuals such as those with implants, as well as a pinching risk for fingers and loose objects.

The user is solely responsible for proper installation and implementation of Nidec product. Mounting and installation instructions contained in this brochure are to be used as guidelines only. The user is responsible for designing mounting interface, stator housing, rotor shaft, and any additional components to be implemented in the intended application.

## Stator Mounting

There are multiple methods to install the Nidec stator into customer-designed housing. Nidec recommends hot dropping and adhesive bonding as two proven methods to install Nidec stators.

**Housing Material:** Nidec recommends an aluminum type housing as the material offers superior heatsink capabilities while maintaining a high strength-to-weight ratio.

### Method 1: Hot Drop Stator into Housing

Hot dropping is a process that uses heat to thermally expand the chosen housing to allow enough clearance for rapid insertion of the stator. Upon cooling, the housing contracts, thus retaining the stator in place.

#### Nidec bases this process on the following assumptions:

- Housing material: Aluminum 6160
- Housing material thickness: 3mm
- Housing heated to 500° F at time of hot drop insertion.
- Once stator is installed, configuration maintains 2mm of axial clearance between stator and any other “live,” conductive material.
- Stator housing is designed with a shoulder on the inner diameter, thus providing a “press-to” locating surface during installation. Temporary tooling could also be used to act as a “press-to” shoulder, and then removed once hot drop process is complete.
- Housing is within inner diameter tolerances per each D-Series size as listed in Table 1.

**Table 1:**  
**Housing Inner Diameter**  
**Tolerances for Hot Drop Method**

Motor Model	Recommended Housing Inner Diameter (mm)
D35	35.43 - 35.53
D52	51.93 - 52.03
D64	63.88 - 63.98
D77	76.88 - 76.98
D100	99.95 - 100.05

**Hot Drop Process:** Heat the aluminum housing to 500° F while the stator is held at room temperature. Upon reaching 500° F, the housing is removed from heat source and the stator is quickly inserted into the aluminum housing. Installation is complete when the stator is fully in contact with “press-to” shoulder located inside of housing. The use of dedicated fixturing can help facilitate the insertion process.

# Mounting & Installation Guidelines

Frameless Brushless DC Motors

## Stator Mounting (Continued)

### Method 2: Adhesively Bond Stator into Housing

An alternative method to hot dropping is to adhesively bond the stator and housing.

#### Nidec bases this process on the following assumptions:

- Adhesive: Loctite 334
- Housing material: Aluminum 6160
- Housing material thickness: 3mm
- Once stator is installed, configuration maintains 2mm of axial clearance between stator and any other “live,” conductive material.
- Stator housing is designed with a shoulder on the inner diameter, thus providing a “press-to” locating surface during installation. Temporary tooling could also be used to act as a “press-to” shoulder, and then removed once bonding process is complete.
- Adhesive manufacturer’s technical data sheet (TDS) is consulted for proper material preparation, curing details, and installation process.
- Operational temperature is not to exceed 150° C; temperatures above 150° C could compromise stator insulation system.
- Target housing diametral clearance ranges are adhered to as listed in Table 2.

**Table 2:**  
**Target Stator Housing**  
**Diametral Clearance**  
**Ranges for Adhesive**  
**Bonding Method**

Motor Model	Recommended Housing Inner Diameter (mm)
D35	35.43 - 35.53
D52	51.93 - 52.03
D64	63.88 - 63.98
D77	76.88 - 76.98
D100	99.95 - 100.05

**Adhesive Bonding Process:** Nidec recommends applying activator to the housing and adhesive to the stator. Consult the adhesive manufacturer’s TDS for all other process recommendations related to adhesive application, material preparation, and curing details.

# Mounting & Installation Guidelines

Frameless Brushless DC Motors

## Stator Mounting (Continued)

**Figure 1:**  
Example Stator Housing  
Details

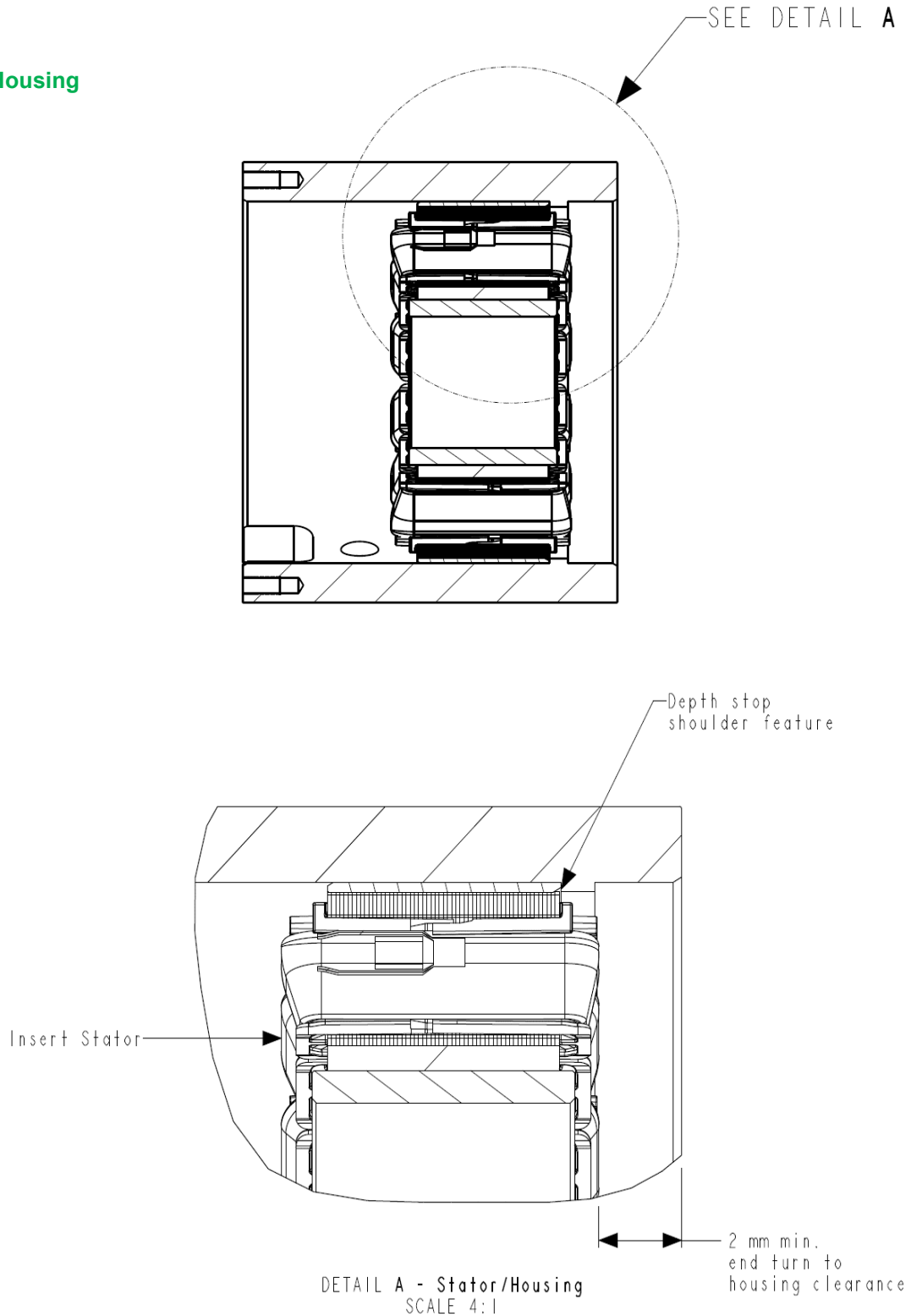

# Mounting & Installation Guidelines

Frameless Brushless DC Motors

## Rotor Mounting

**Shaft Material:** Nidec recommends common grade carbon or 316 stainless steel for shaft material selection.

### Method: Press Fit Rotor onto Shaft

Nidec recommends utilizing a press fit operation to install Nidec rotor onto customer-designed shaft.

Nidec bases this process on the following assumptions:

- Shaft material: 316 stainless steel
- Components are at room temperature.
- No lubrication present on mating surfaces of rotor or shaft.
- Shaft designed with lead-in chamfer to assure uniform installation of rotor.
- Shaft designed according to interference tolerance ranges and associated press force ranges as recommended in Table 3.

**Table 3:**  
Shaft Interference  
Tolerance and Press  
Force Ranges for Rotor  
Installation

Motor Model	Theoretical Press Force Range for Assembly (lbs)	Recommended Shaft Interference Range (mm)
D35	1,750 – 10,000	0.0075 – 0.0405
D52	850 – 5,000	0.007 – 0.040
D64	1,750 – 10,000	0.007 – 0.040
D77	1,300 – 9,000	0.006 – 0.039
D100	1,100 – 7,000	0.006 – 0.039

**Press Fit Rotor onto Shaft Process:** User places rotor in fixture designed to hold rotor upright while allowing the shaft to pass through as it is pressed into target location. (See graphic below for example fixture apparatus.) Shaft is pressed into place using uniform, controlled force, ensuring that no pressing force is applied to the rotor magnets. If tolerances are challenging to hold, wicking grade Loctite 290 can be used to reinforce looser fits

**Figure 2:**  
Example Rotor Installation  
Fixture

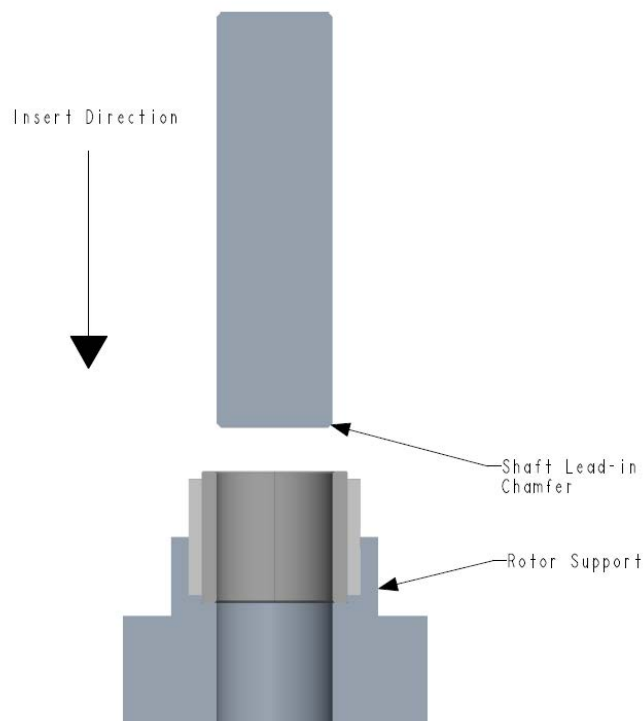



# Mounting & Installation Guidelines

Frameless Brushless DC Motors

## Rotor and Stator Alignment

---

It is important that concentricity and axial alignment are maintained during and after installation so as not to compromise motor performance. Reference product drawings for position details. Use caution while coupling rotor and stator, as the strong attractive force of the magnets can create a pinching hazard during installation. Without proper control, the magnetic force can cause the rotor to “snap” into the stator, which could result in chipped magnets or other damaged motor components. Any damage to the motor could result in reduced motor performance and/or pose a safety hazard. Nidec recommends using a thin piece of mylar as a shim between the stator and rotor during installation to help prevent direct contact between rotor magnets and stator. After coupling the rotor and stator in the application, remove the mylar shim and ensure the rotor moves freely inside the stator with no striking.

## Performance Data – Thermal

---

### Setup

Nidec conducted heat rise performance tests by running D-Series frameless motors inside custom housings. Type J thermocouples were placed on each phase and the housing to capture temperatures. The housed motor was coupled to a dynamometer using a flexible coupling. A shroud corrugated “chamber” was placed over this arrangement to minimize influence of the ambient surroundings. The drive used in this experiment, RoboteQ MBL 1660A, was placed outside of the controlled environment.

### Process

The motors were run on the dynamometer. The load on the dynamometer was steadily increased up to the rated torque that corresponds to each motor size until the motor winding temperature stabilized at around 150°C. The graphs that follow show the elapsed time for each motor to stabilize at 150°C under rated torque, as well as the speed-torque performance data for each motor size.

### Operating and Environmental Conditions:

- Ambient temperature during testing: ≈40°C
- Wall thickness of housing: 8.43mm
- Housing material: Aluminum 6061

# Mounting & Installation Guidelines

Frameless Brushless DC Motors

## Performance Data – Thermal (Continued)

**Figure 3:**  
Heat Rise Performance  
Test Chamber and Fixture  
Cross Section

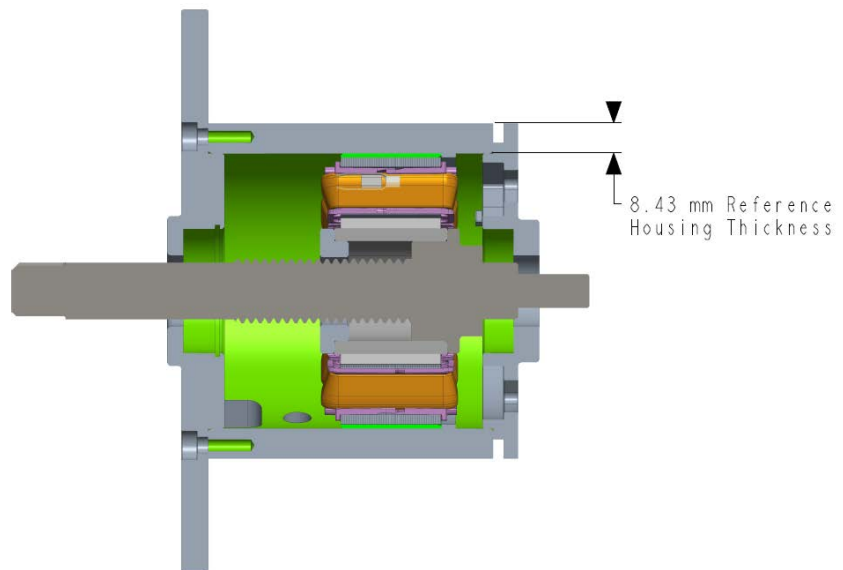
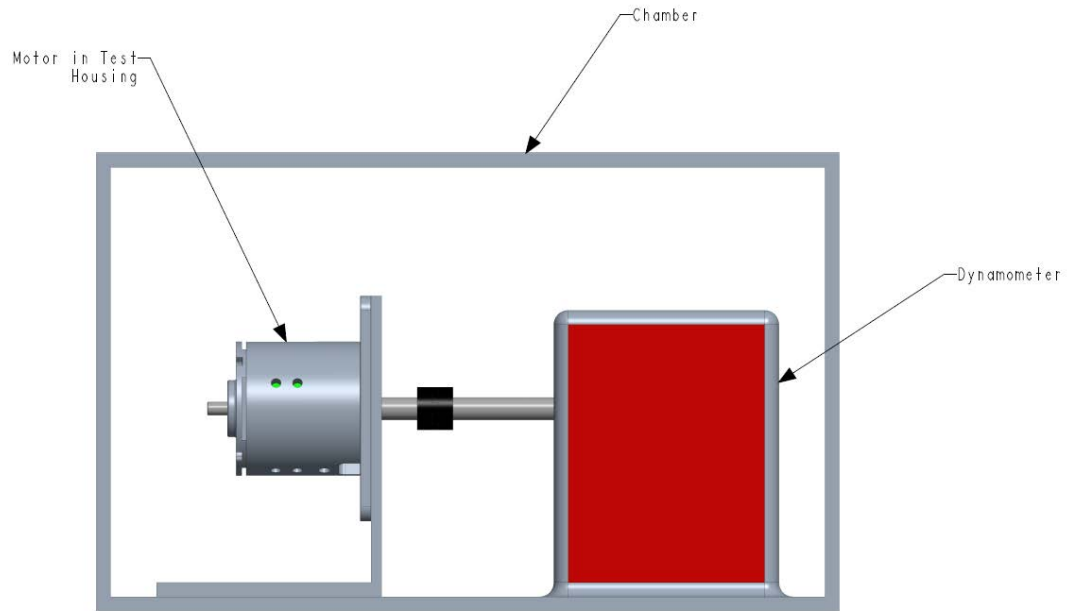

# Mounting & Installation Guidelines

Frameless Brushless DC Motors



## Performance Data – Thermal (Continued)

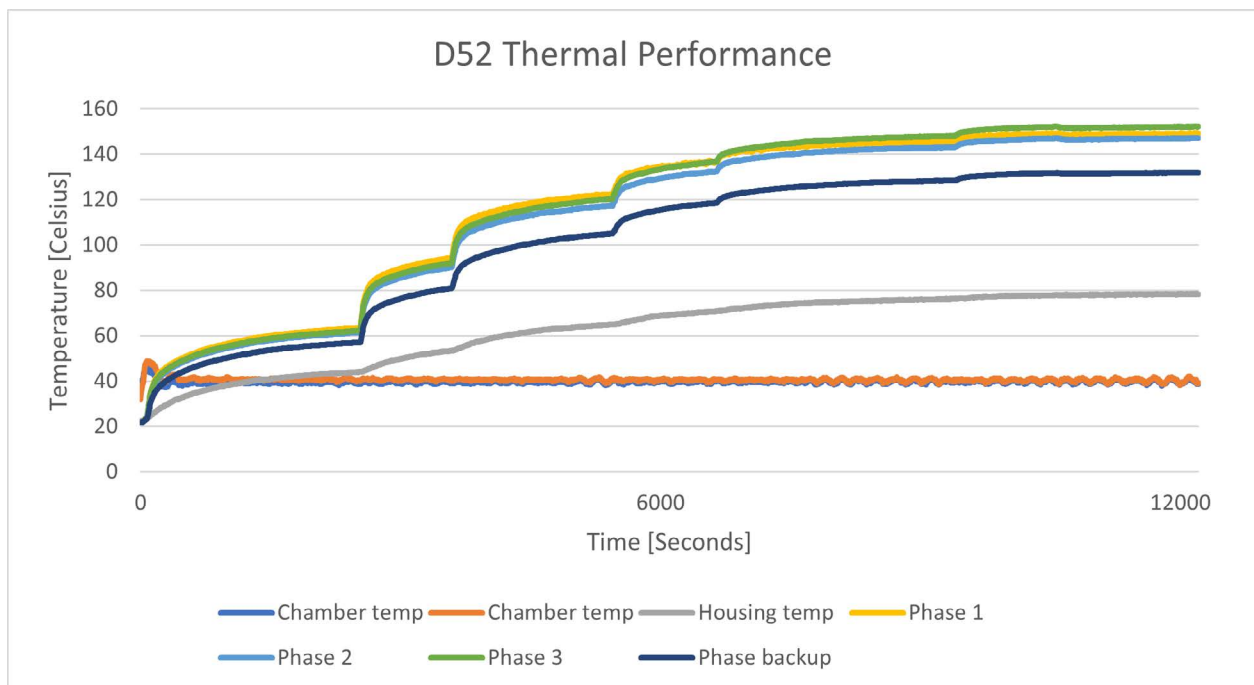
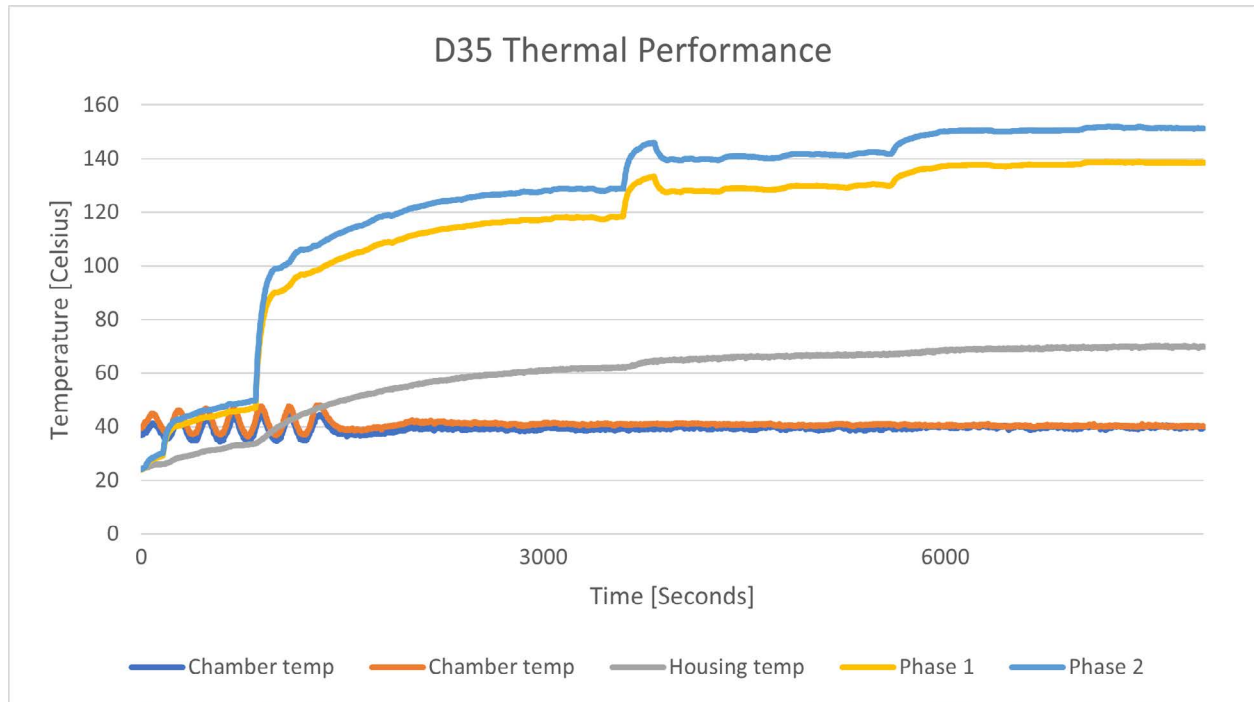

# Mounting & Installation Guidelines

Frameless Brushless DC Motors



## Performance Data – Thermal (Continued)

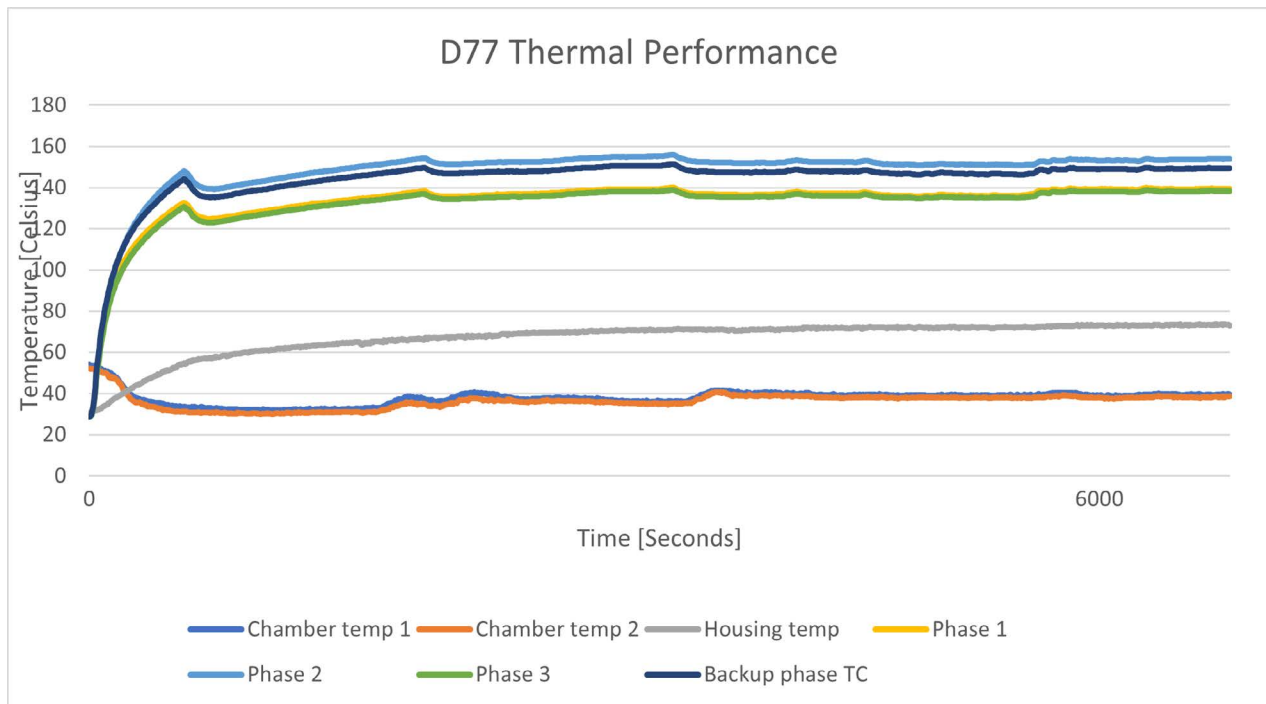
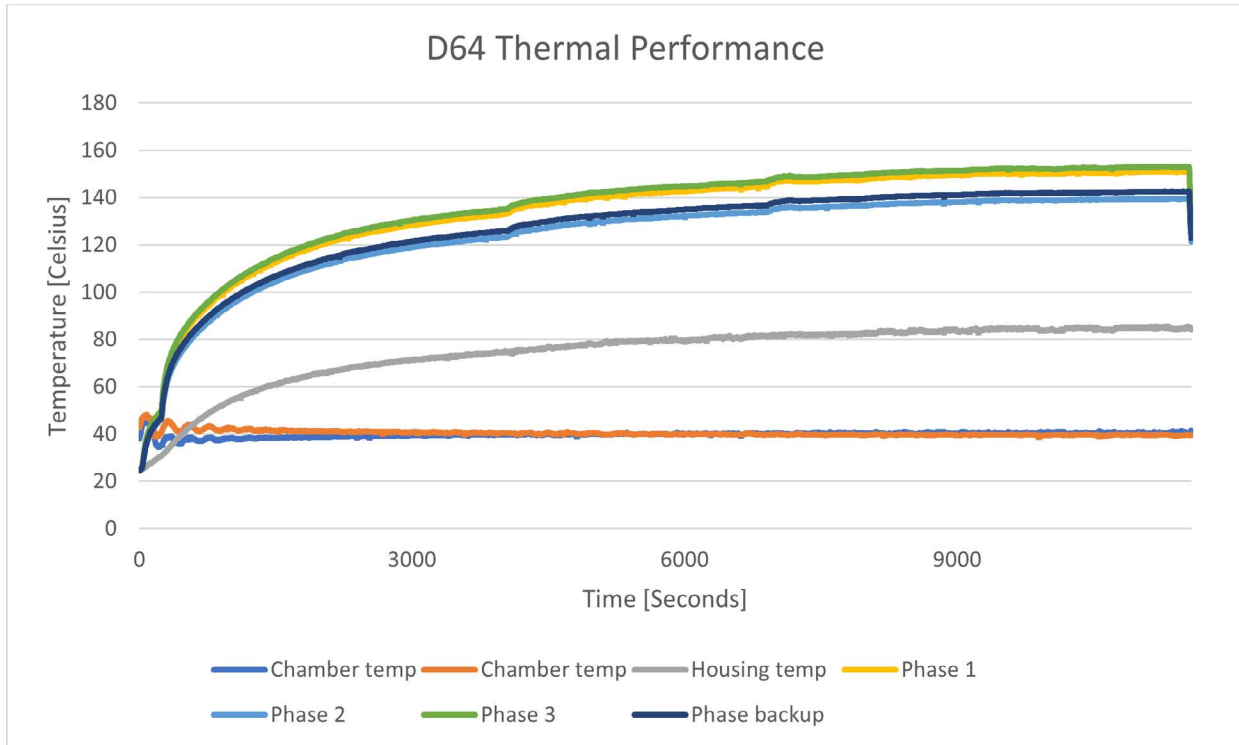

# Mounting & Installation Guidelines

Frameless Brushless DC Motors

## Performance Data – Thermal (Continued)

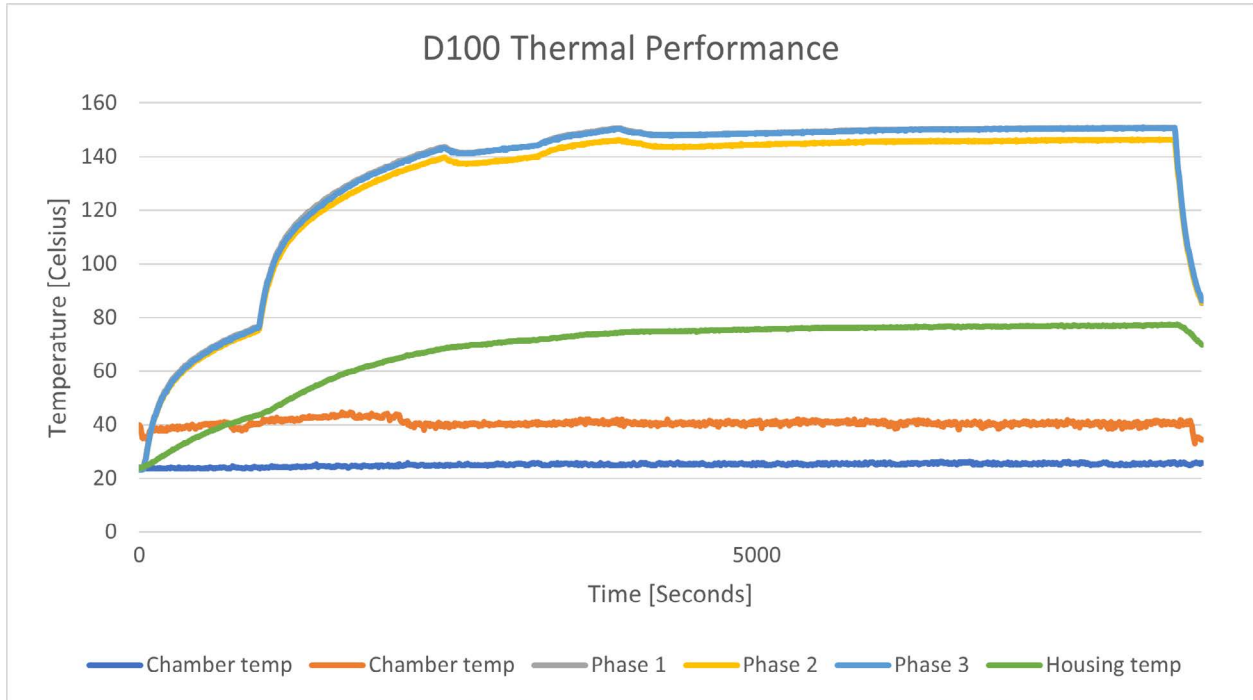

# Mounting & Installation Guidelines

Frameless Brushless DC Motors

## Performance Data – Speed-Torque

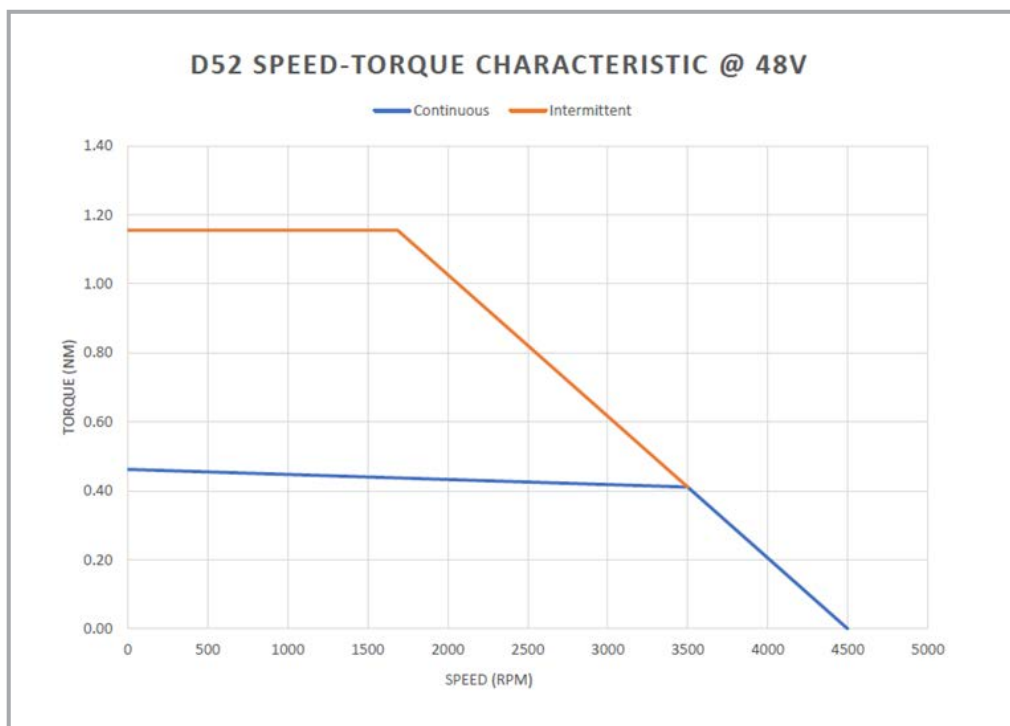
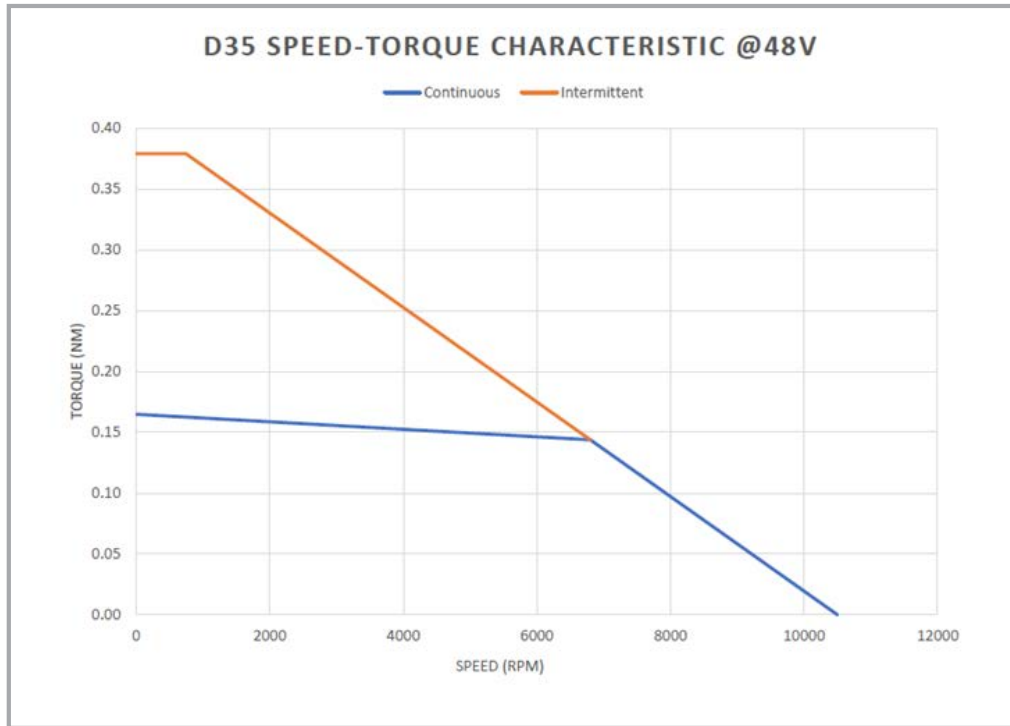

# Mounting & Installation Guidelines

Frameless Brushless DC Motors

## Performance Data – Speed-Torque (Continued)

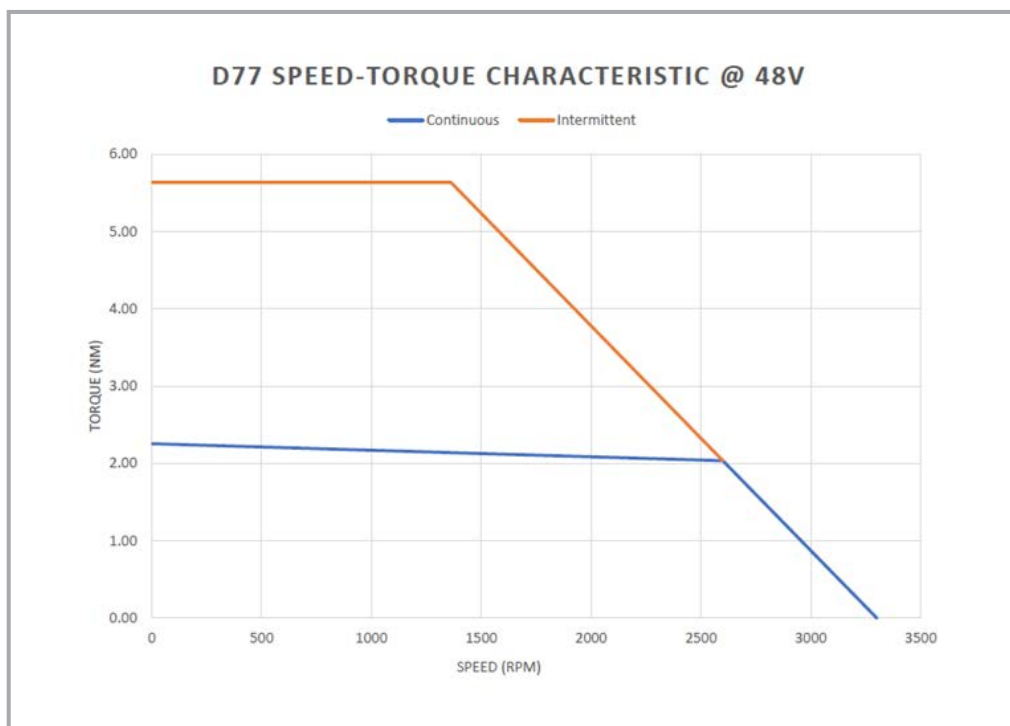
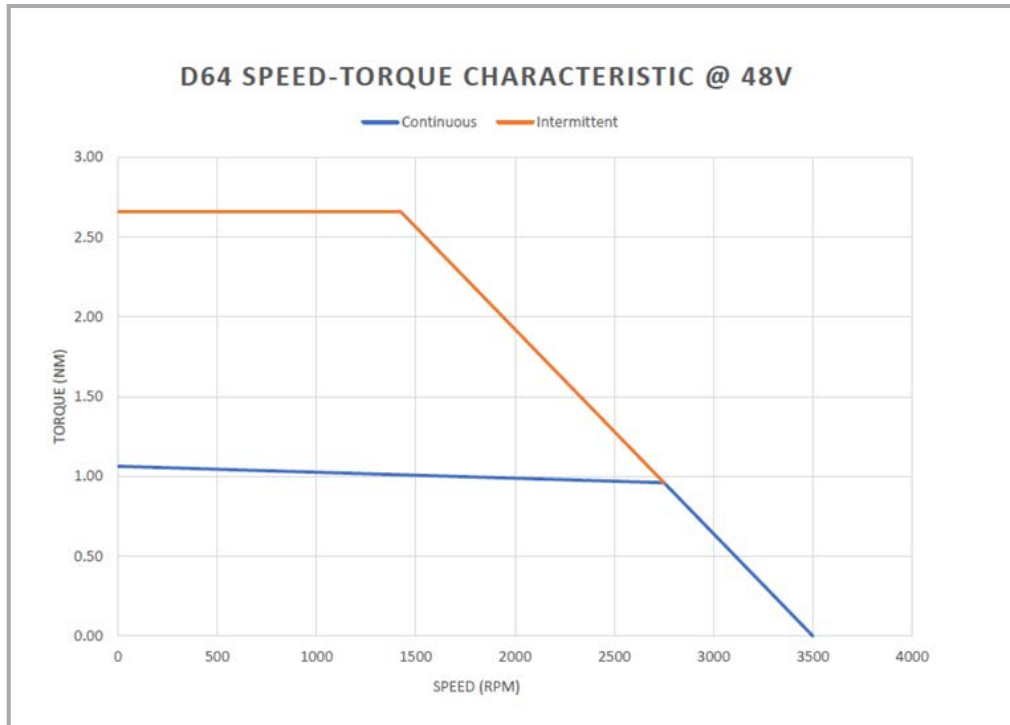

# Mounting & Installation Guidelines

Frameless Brushless DC Motors

## Performance Data – Speed-Torque (Continued)

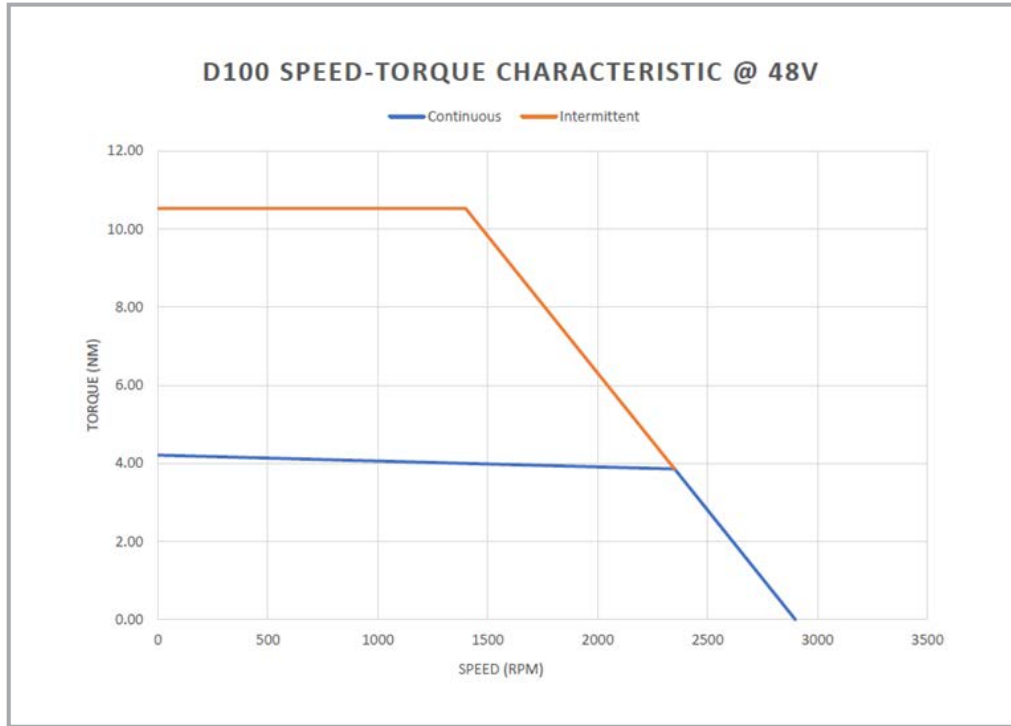



## About Nidec Corporation

---

Nidec Corporation is an international conglomerate originally known for having the most significant global market share of small precision motors. Exponential growth through mergers and acquisitions over the past few decades means that Nidec now manufactures motors spanning the spectrum from those original tiny motors to much larger motors powering heavy commercial and industrial equipment. This is one of the reasons it's said that Nidec specializes in "everything that spins and moves."

Headquartered in Kyoto, Japan, Nidec started with only four employees in 1973 and has grown to include more than 300 subsidiary companies with over 140,000 workers in over 30 countries across the globe.



Corporate Head Office  
Kyoto, Japan

## About Nidec Motor Corporation

---

Nidec Motor Corporation (NMC), a major subsidiary of Nidec Corporation, was formed in 2010 when Nidec Corporation acquired the motors and controls business of Emerson Electric Company. Headquartered in St. Louis, Missouri U.S.A., Nidec Motor Corporation produces a vast array of motors and controls for the appliance, commercial, and industrial sectors. NMC has 10 manufacturing facilities in the U.S., Mexico, the UK and China. Additionally, there are 15 technology, administration and distribution locations in the U.S., Canada, Mexico, Venezuela, Columbia, China and the Philippines.



NIDEC MOTOR CORPORATION



Nidec Motor Corporation  
St. Louis, Missouri U.S.A.

## About Nidec Motion and Drives

---

Nidec Motion and Drives is a business unit within NMC specializing in standard and custom brushless DC motors, AC and DC servo motors, frameless motors, and brushed PMDC motors, to name a few. Motion Control designs and mass manufactures sophisticated electric motors and drives/controllers for AGVs, robotics, HVLS fans, marine applications, and many more. Motion Control's customer-centric approach is to serve as a developmental partner, providing innovative solutions for some of the world's most challenging and demanding motor, gearmotor and drive applications.



MOTION & DRIVES

[www.NidecMotion.com](http://www.NidecMotion.com)

(314) 595-8782

[Contact Us Form](#)

Nidec Motion and Drives strives for personalized service with dedicated project teams that lead and collaborate from concept to design, and from rapid prototyping to production. These teams focus on delivering the right mechanical package for the application, either by leveraging diverse standard platforms or providing a customized solution. Backed by the global network of Nidec expertise and experience, the end result is a quality product that meets customer requirements on time and at the right price.

